

**ELECTRICITY DIVIDE**

**8210-02 ENGINE ROOM FUSE & RELAY BOX CIRCUIT**

**(1) SB1, SB3, SB4, CONDENSOR FAN RELAY (HI, LO)**

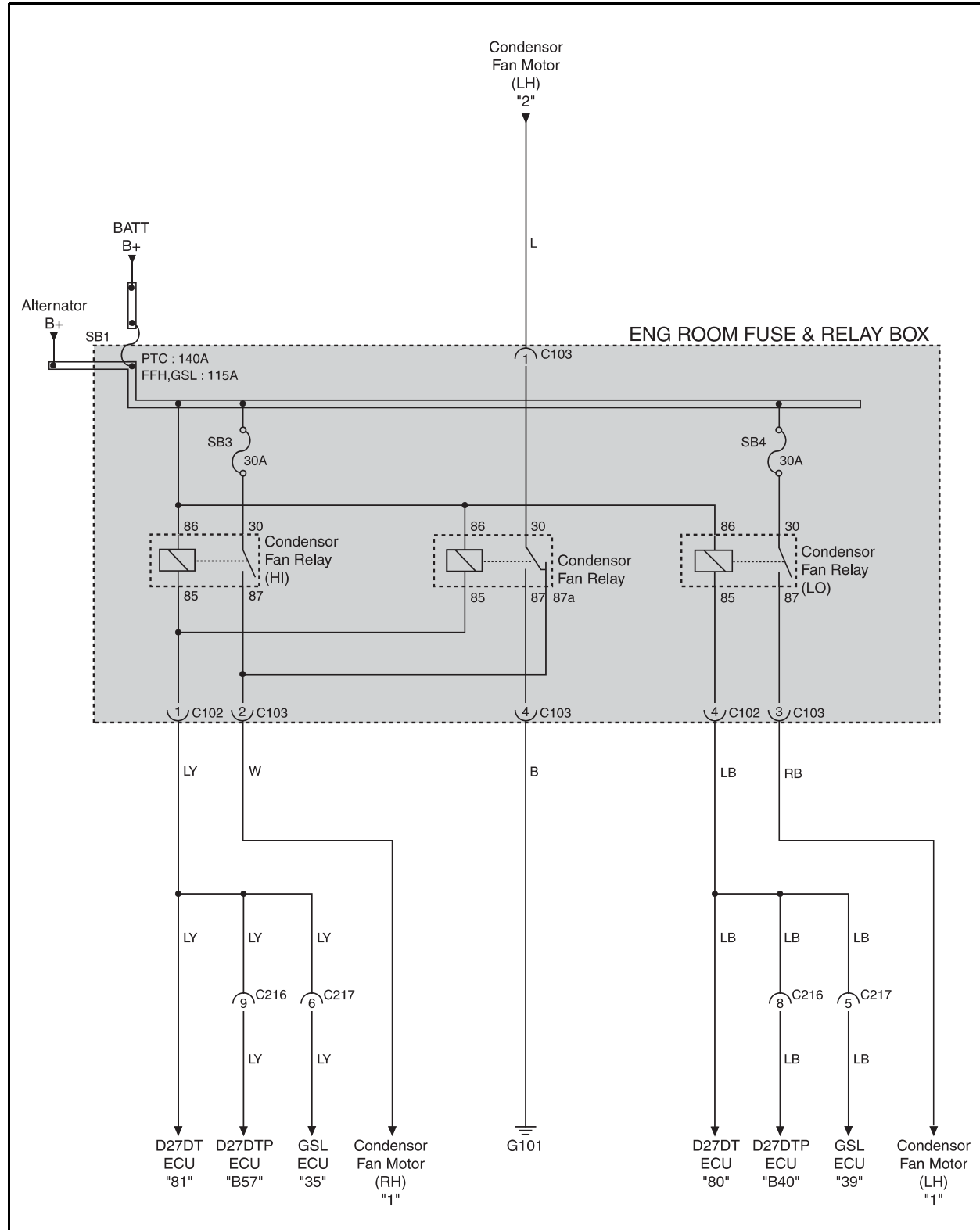

**(2) SB5 ~ SB8, EF5, EF6, ENG MAIN RELAY, START RELAY**

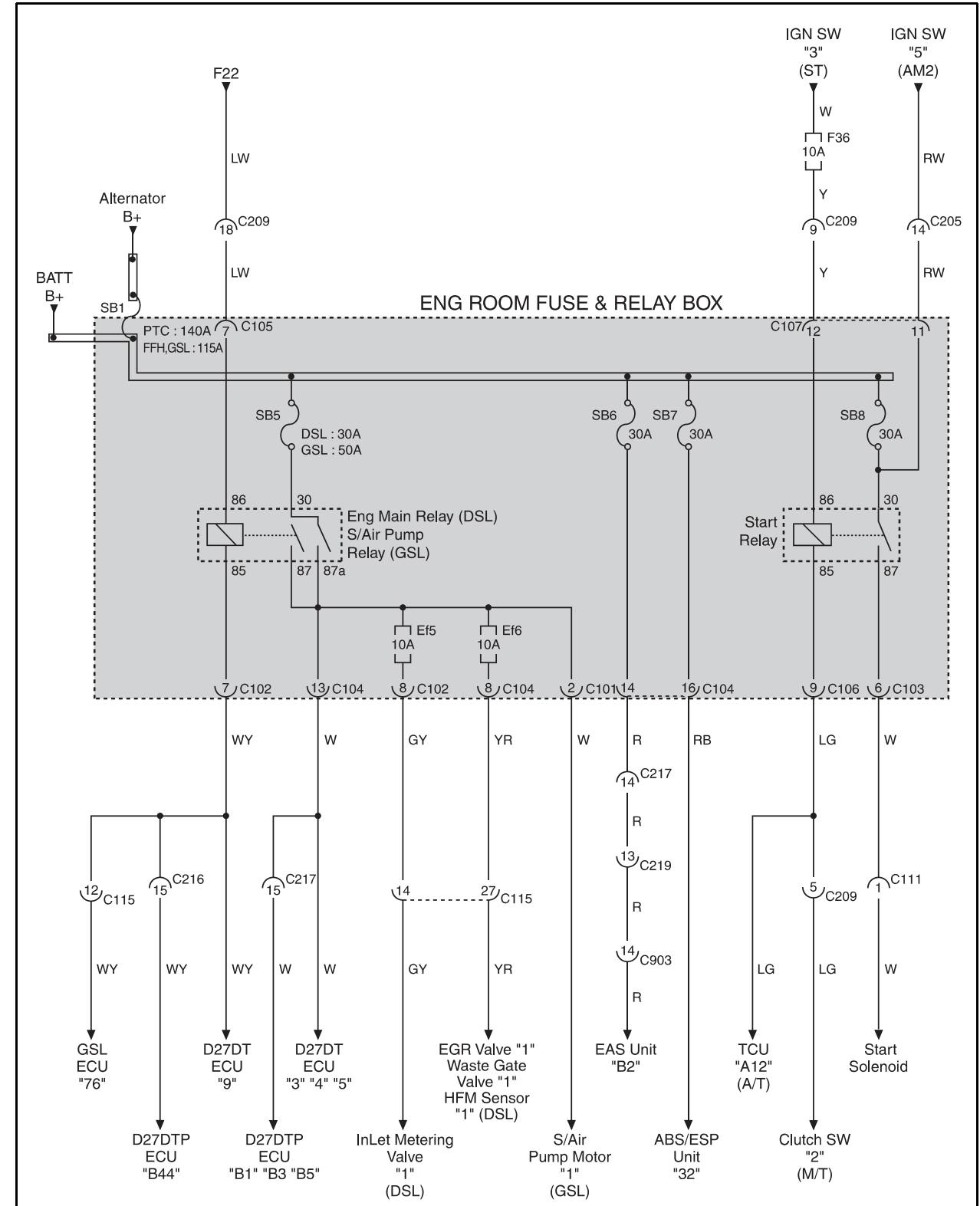

Modification basis	
Application basis	
Affected VIN	

(3) SB9 ~ SB11, EF1, EF2, DEICER RELAY, HORN RELAY

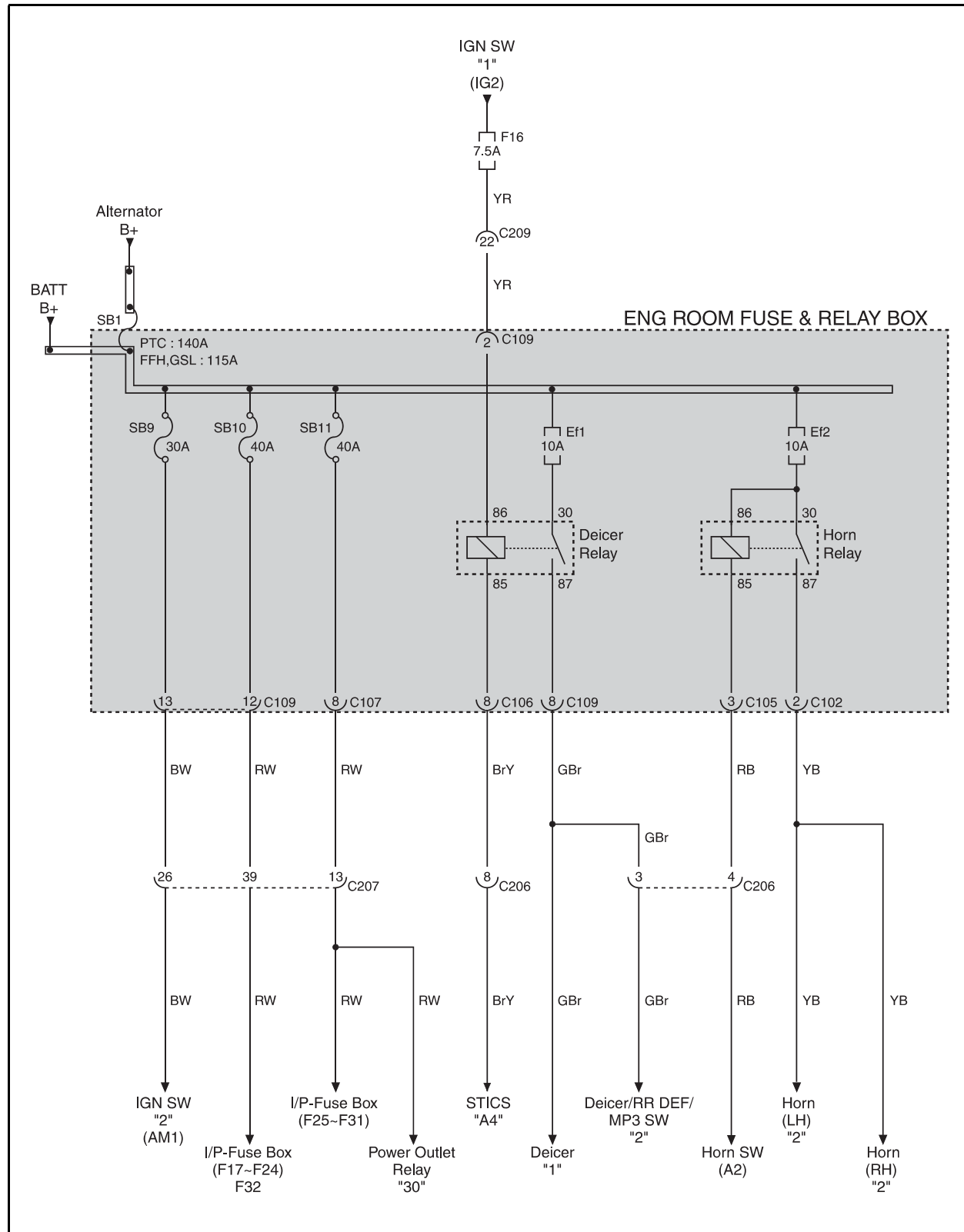

(4) EF3, EF4, EF19, EF20, HEAD LAMP RELAY(HI, LO), COMP RELAY, ENG MOUNT CONTROL RELAY

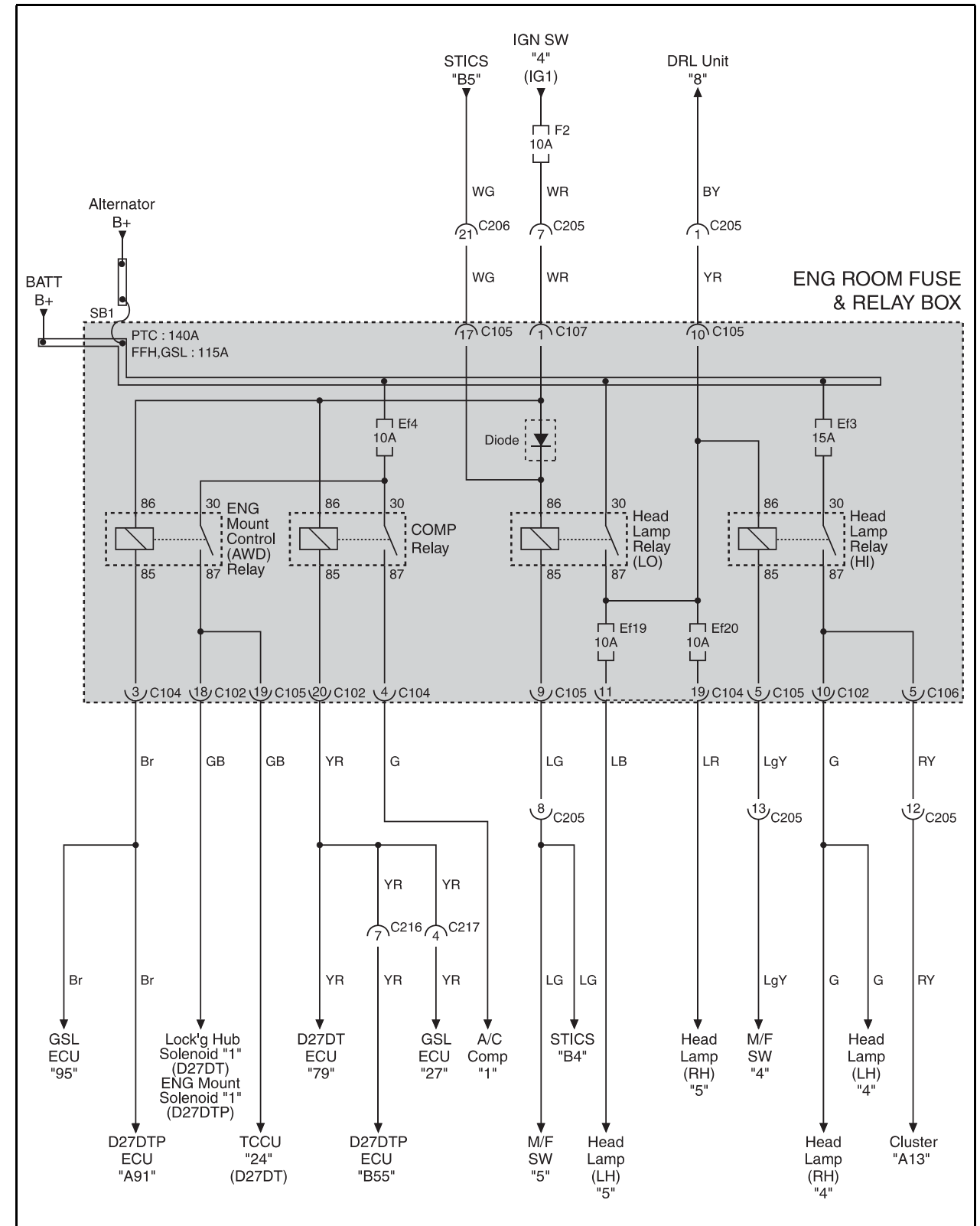

Modification basis	
Application basis	
Affected VIN	

(5) EF7 ~ EF9, EF21, TAIL LAMP RELAY, FRT FOG LAMP RELAY

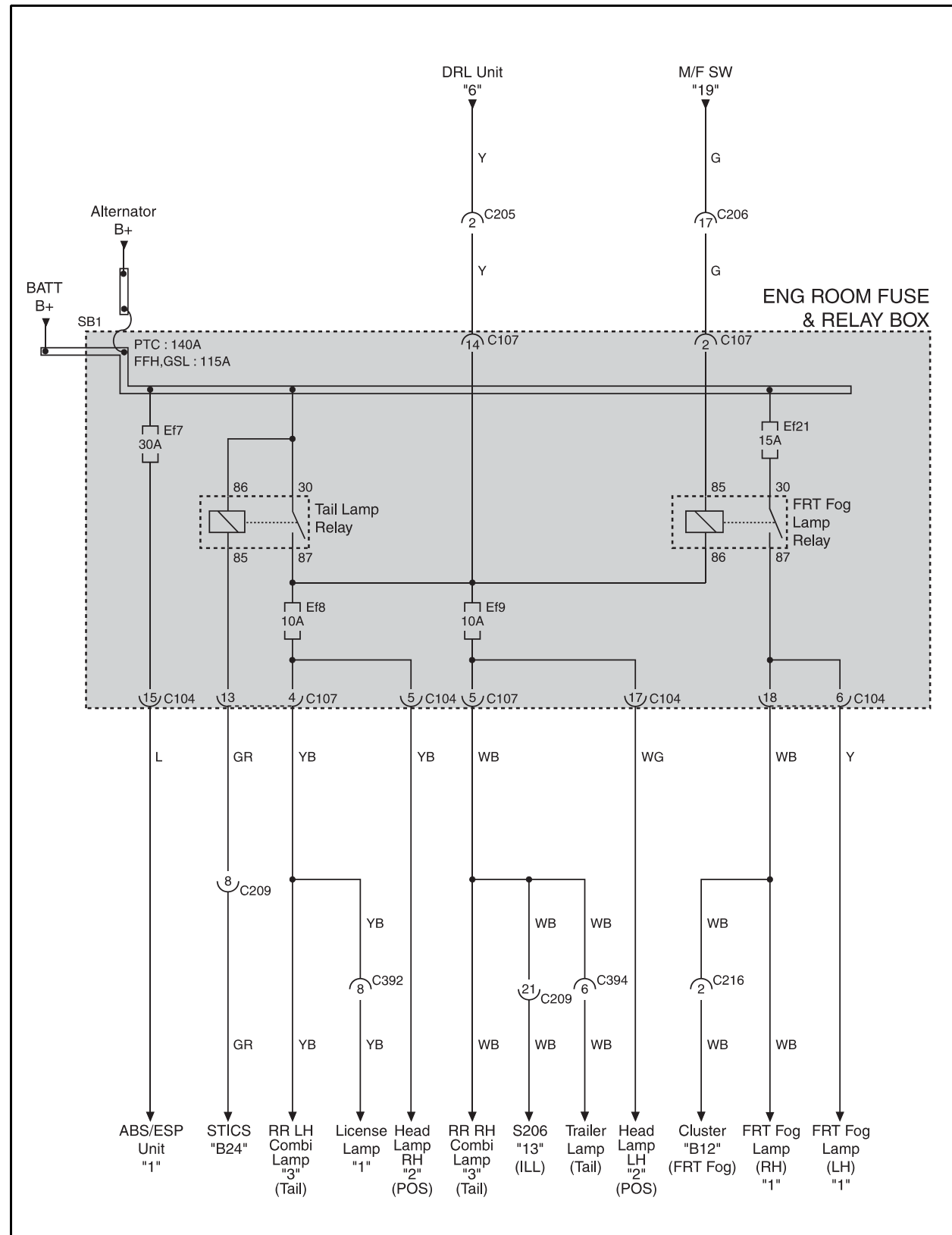

(6) EF10 ~ EF13, EF17, EF18, EF23, RR DEF RELAY

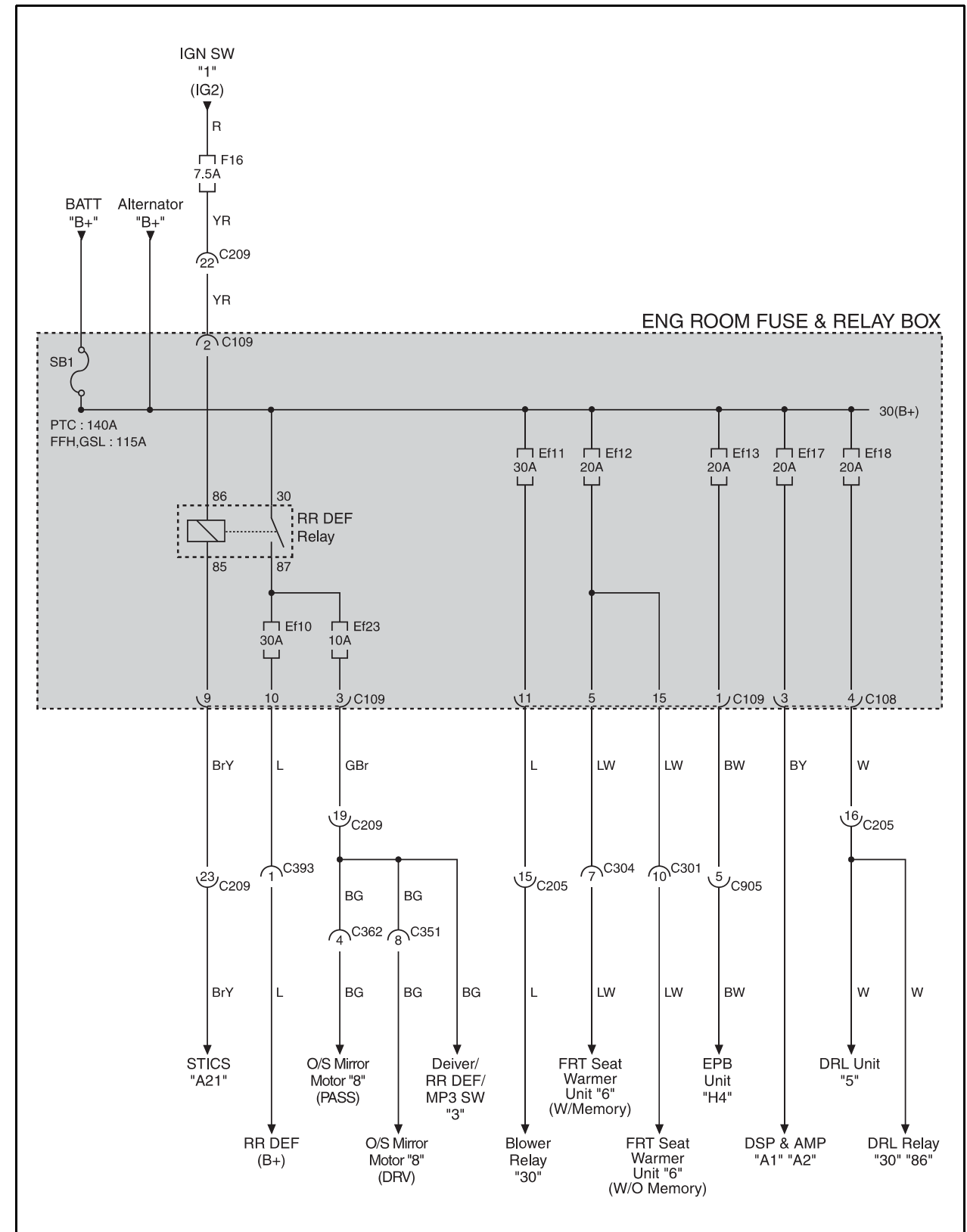

Modification basis	
Application basis	
Affected VIN	

(7) EF14 ~ EF16, EF22, EF24 ~ EF26, POWER WINDOW RELAY

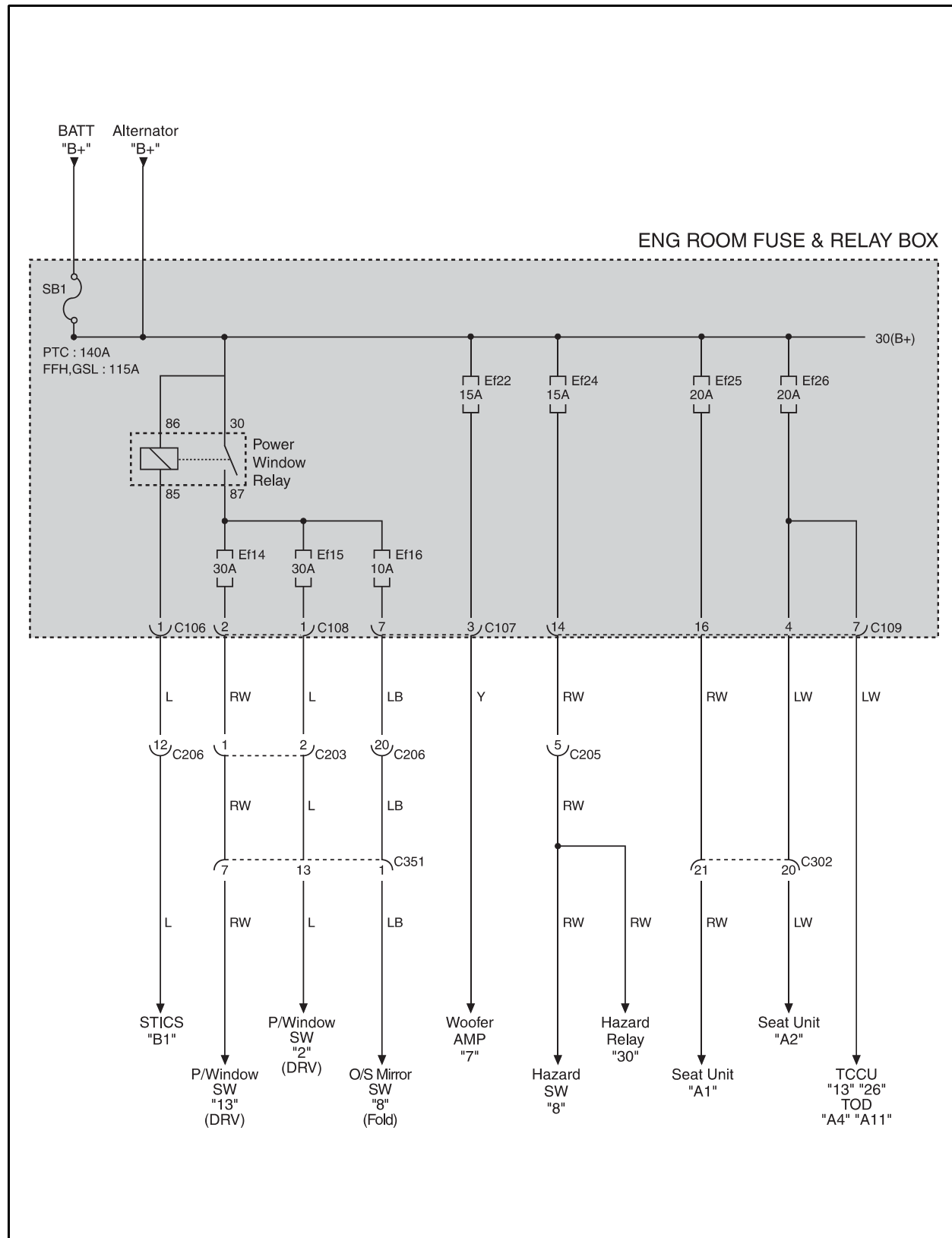

(8) FRT WIPER MOTOR RELAY(LO)

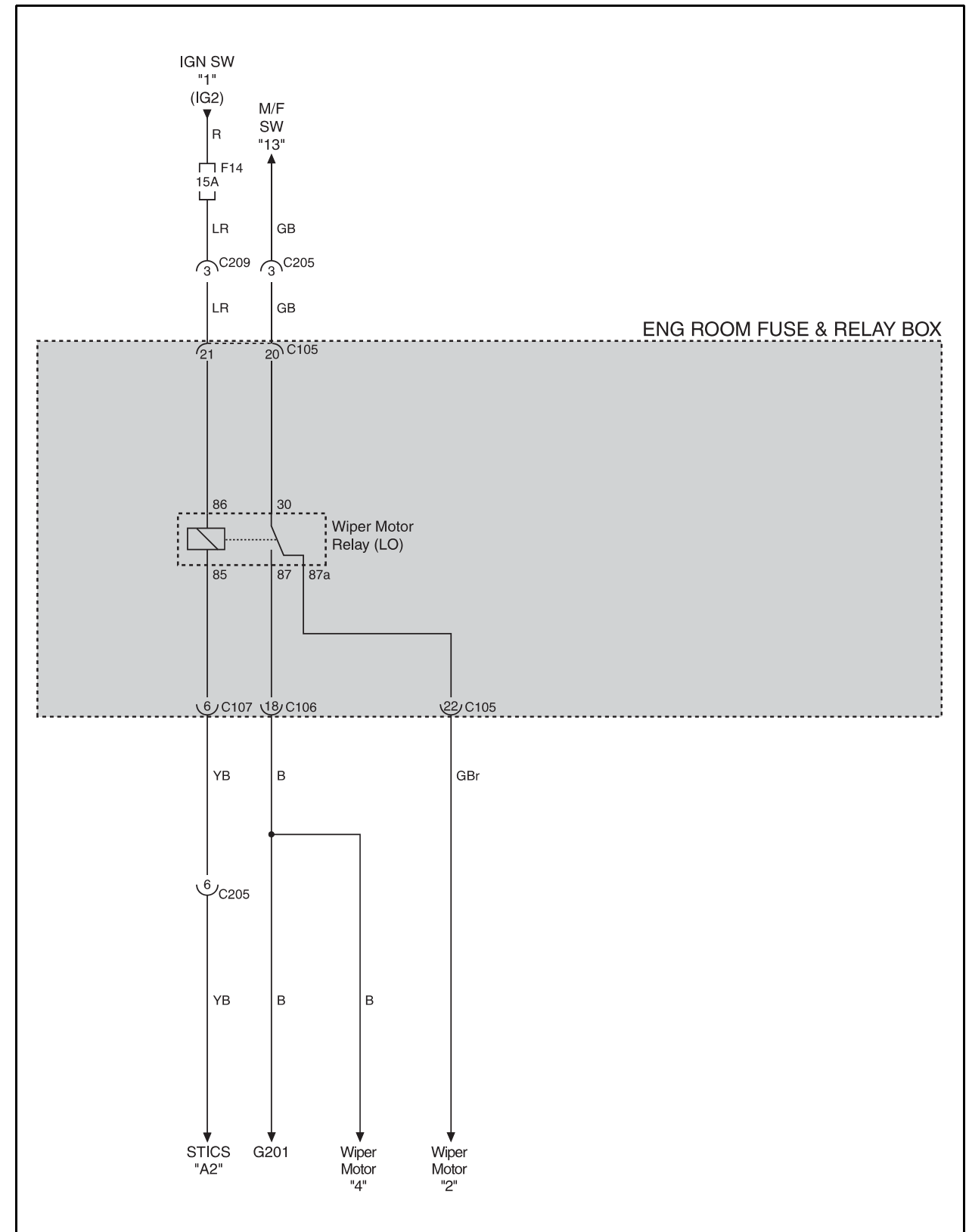

Modification basis	
Application basis	
Affected VIN	

**8410-04 I/P - FUSE BOX CIRCUIT**

**(1) F1 ~ F5**

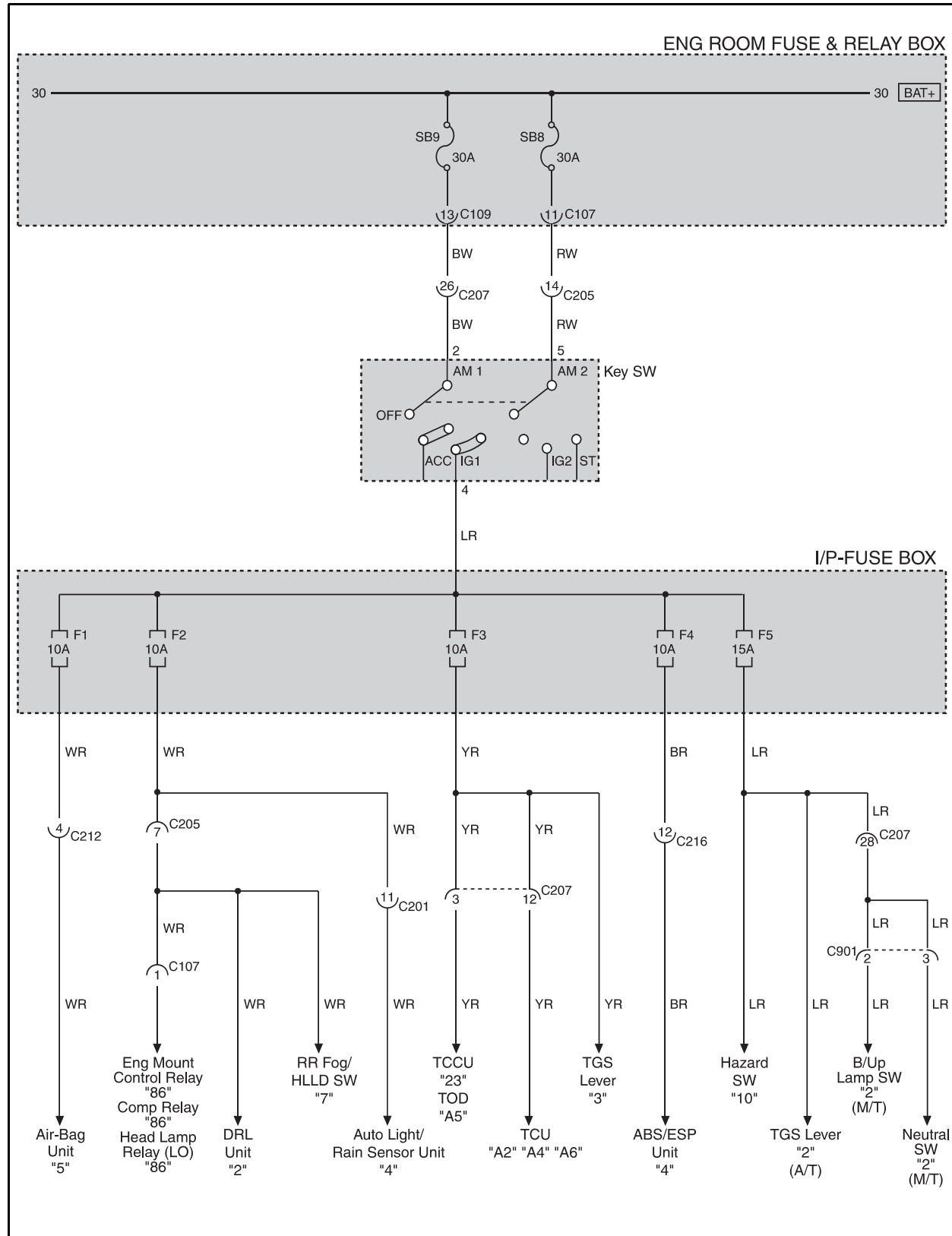

**(2) F6 ~ F10**

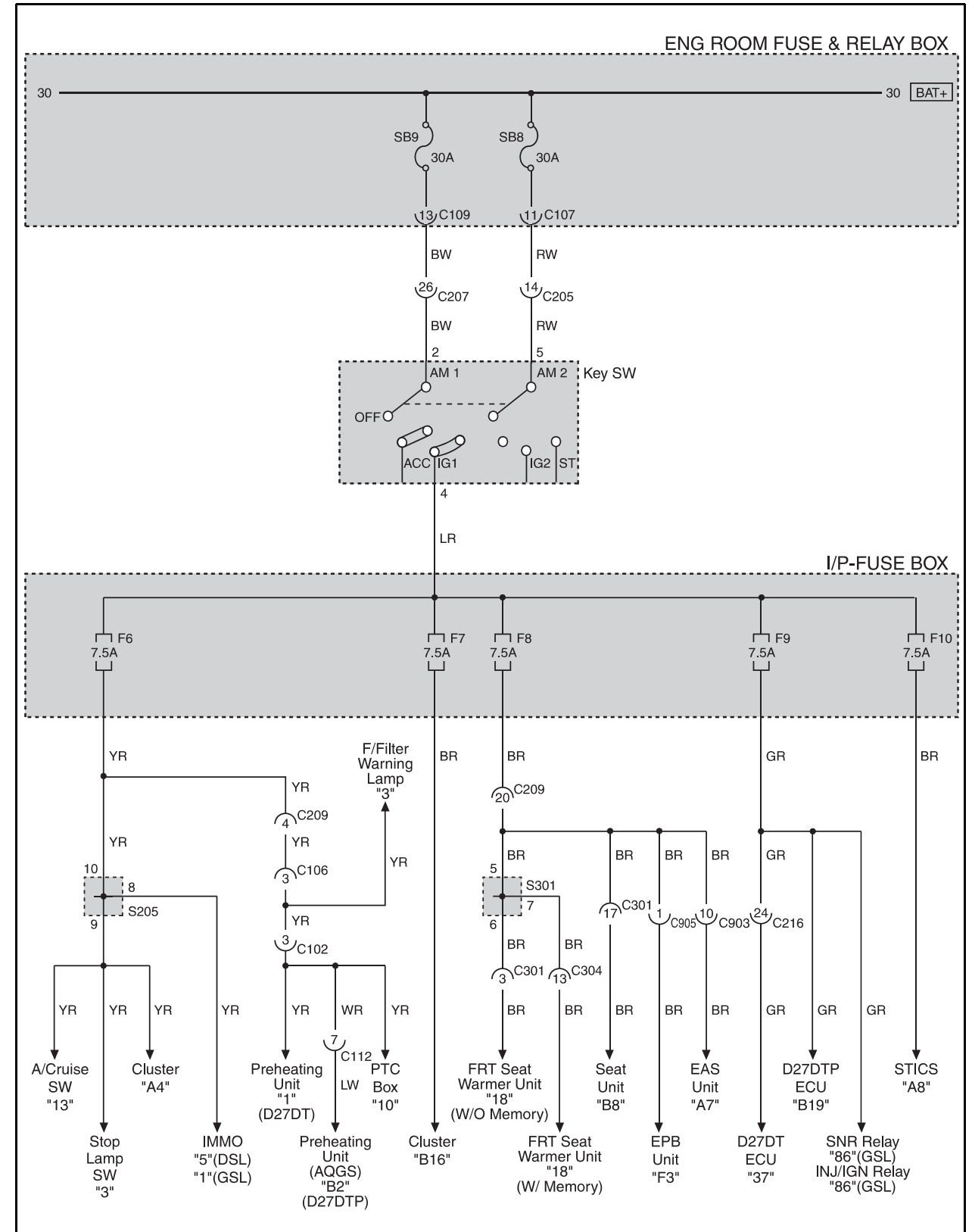

Modification basis	
Application basis	
Affected VIN	

(3) F11 ~ F15

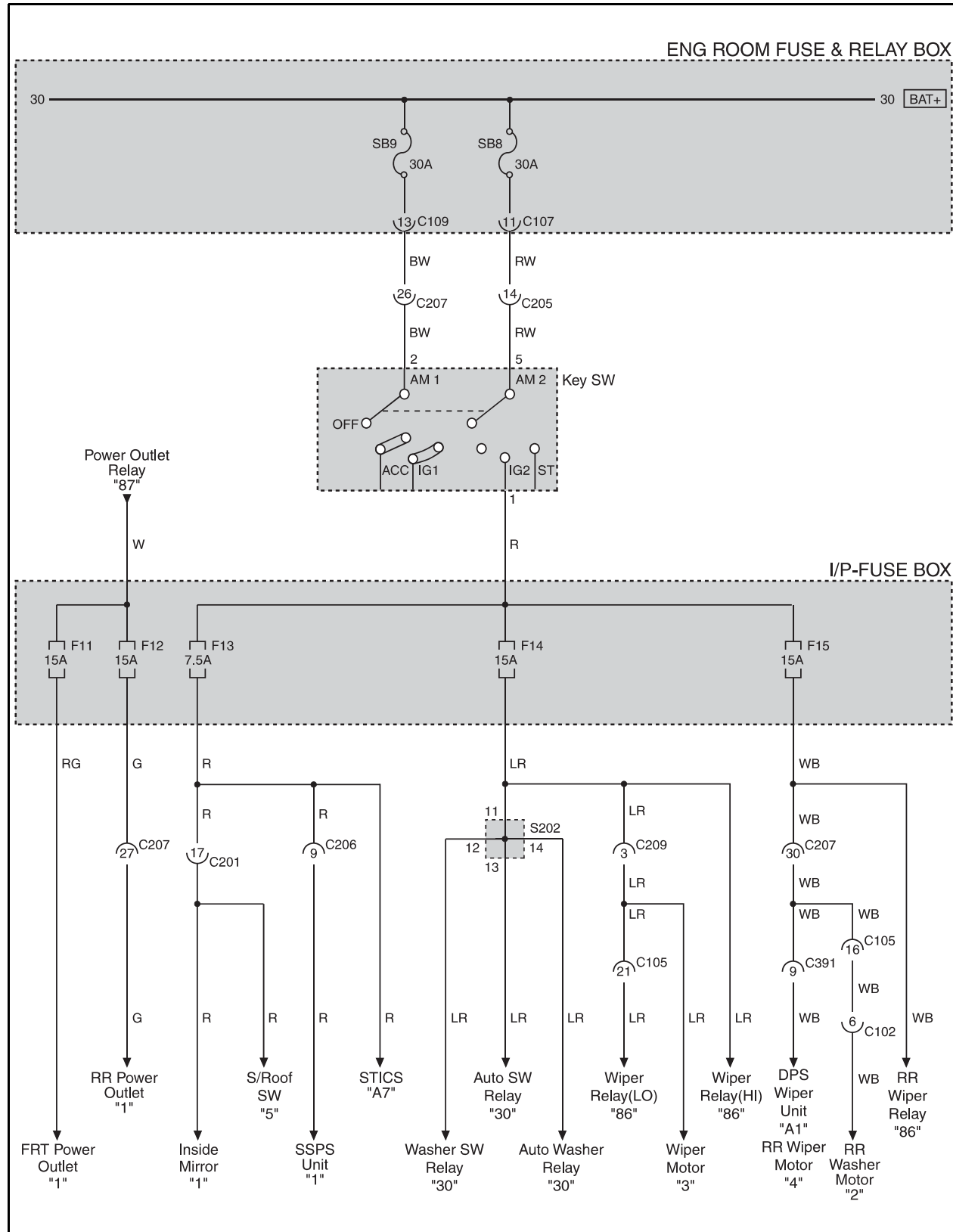

(4) F16 ~ F22

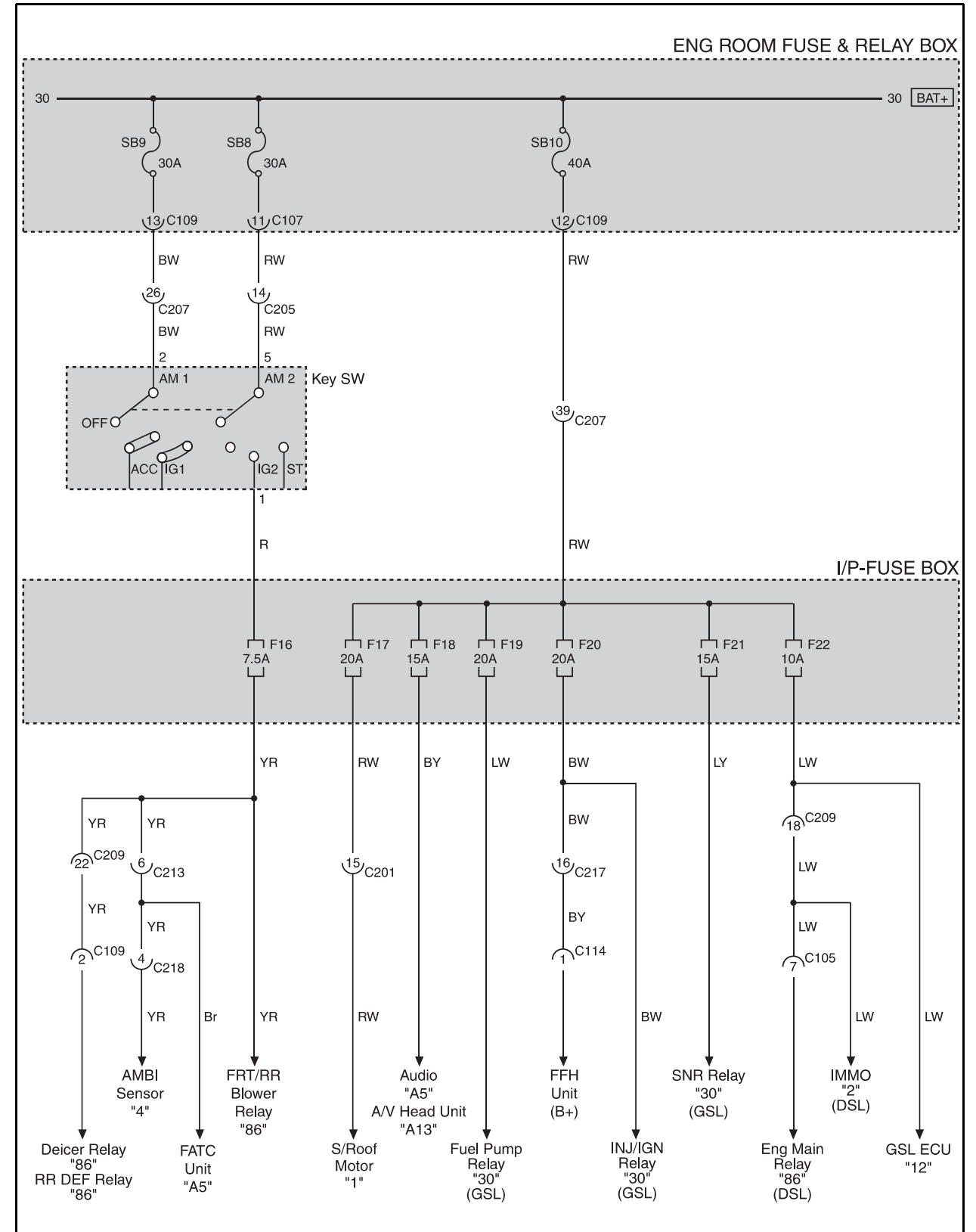

Modification basis	
Application basis	
Affected VIN	

(5) F23 ~ F26, F32

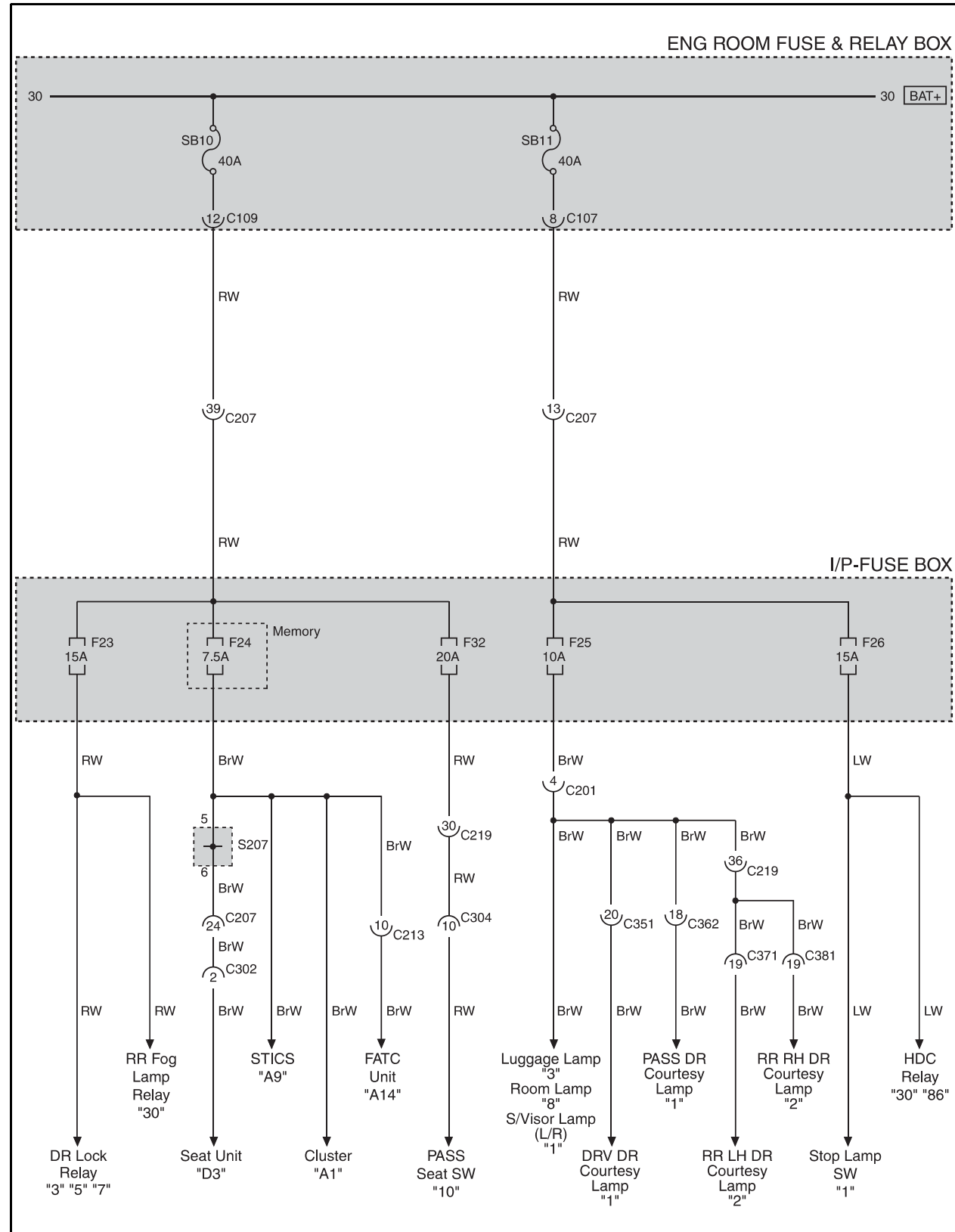

(6) F27 ~ F31

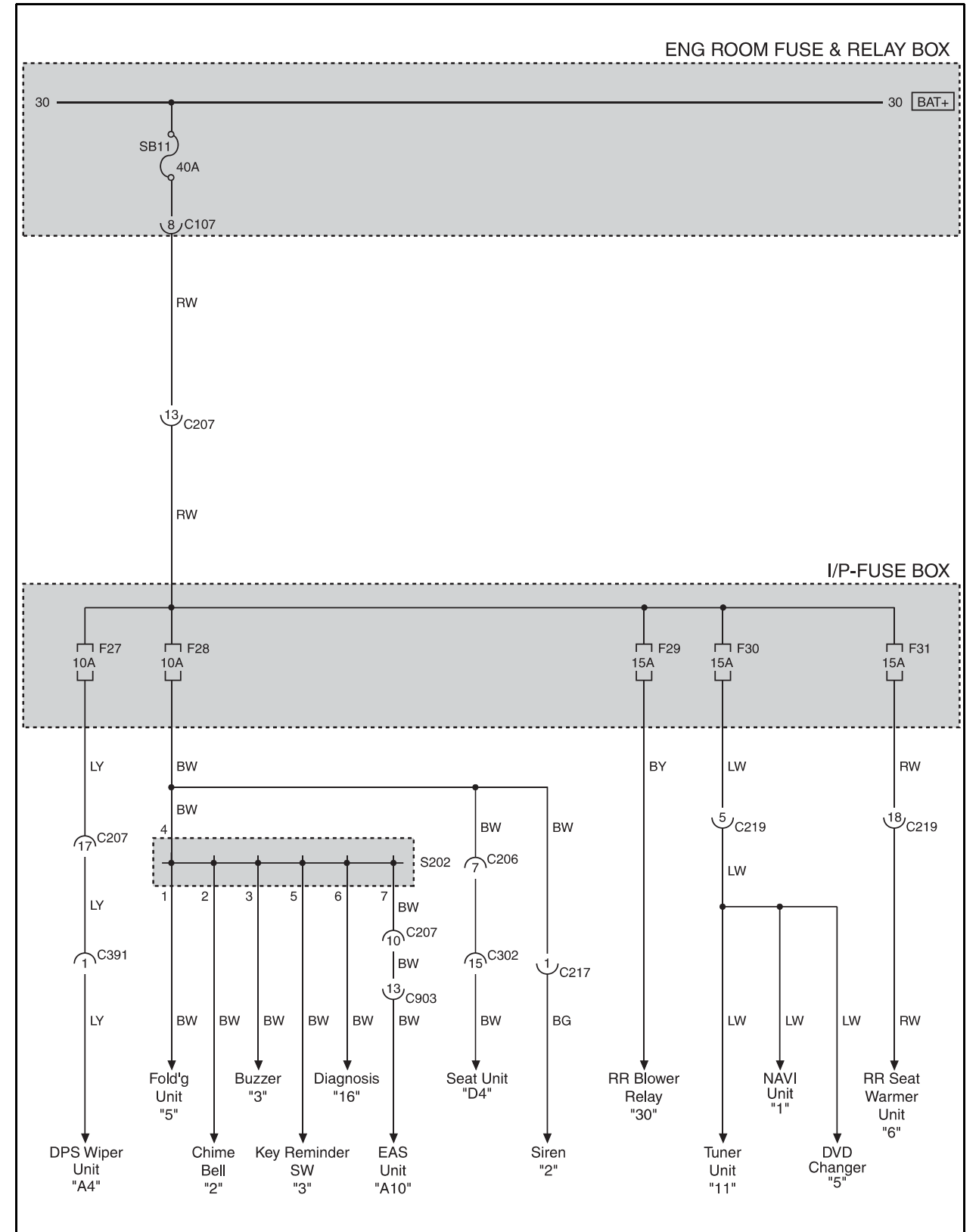

Modification basis	
Application basis	
Affected VIN	

(7) F33 ~ F36

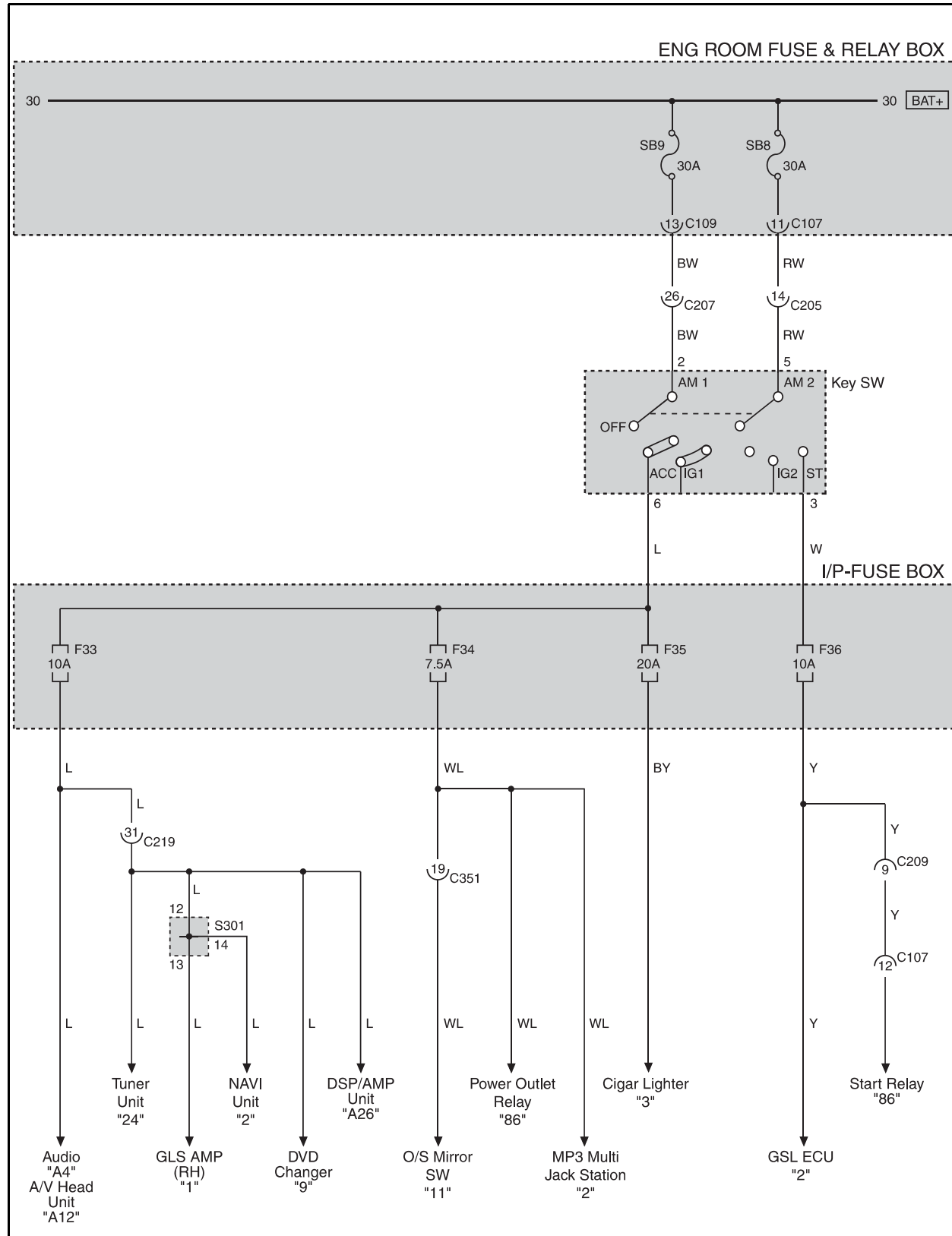

Modification basis	
Application basis	
Affected VIN	



**8410-06 I/P - RELAY BOX CIRCUIT**

**(1) POWER OUTLET RELAY, BLOWER RELAY(FRT,RR), HDC RELAY**

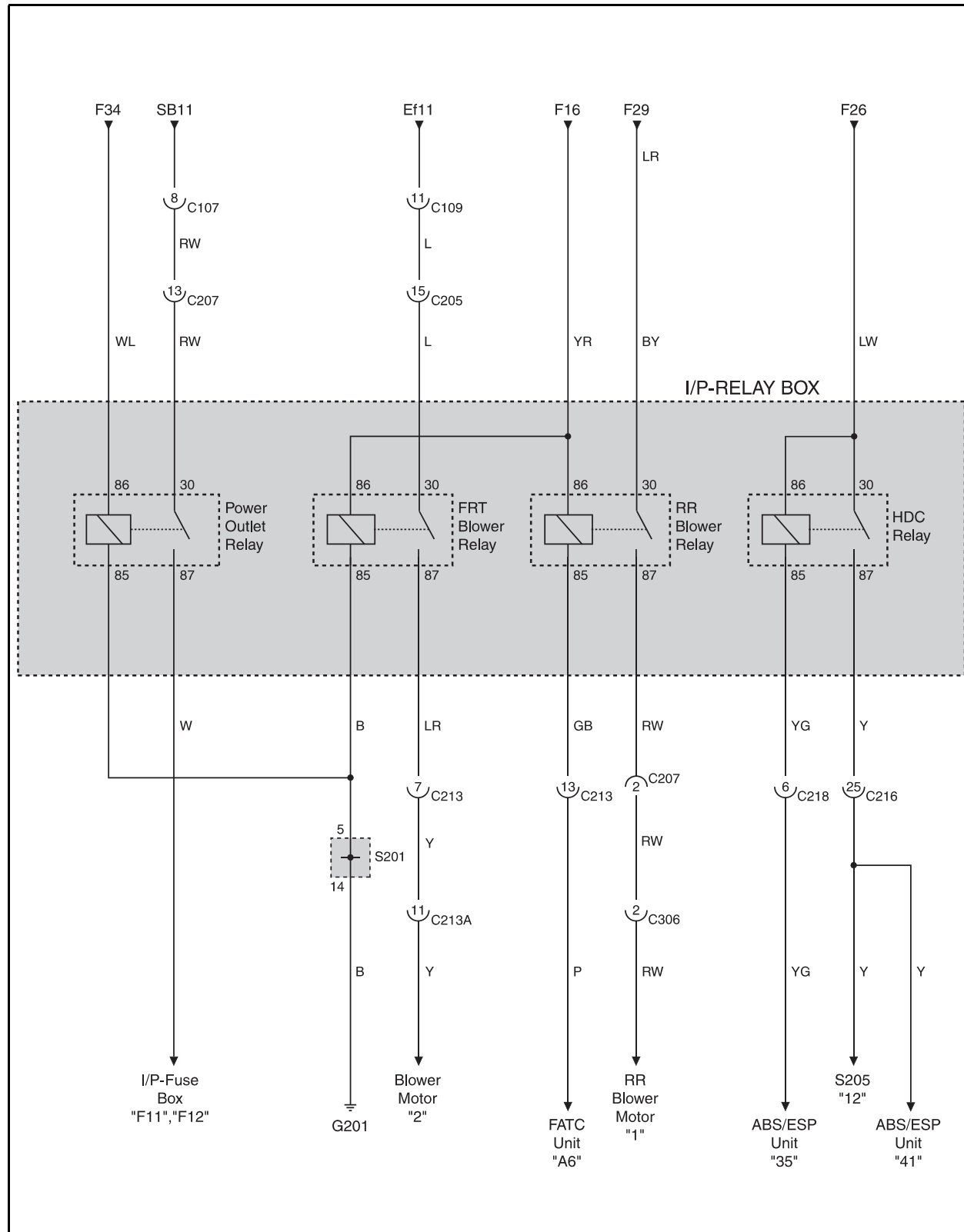

**(2) WIPER RELAY(HI), WASHER SW RELAY, AUTO SW RELAY, AUTO WASHER RELAY**

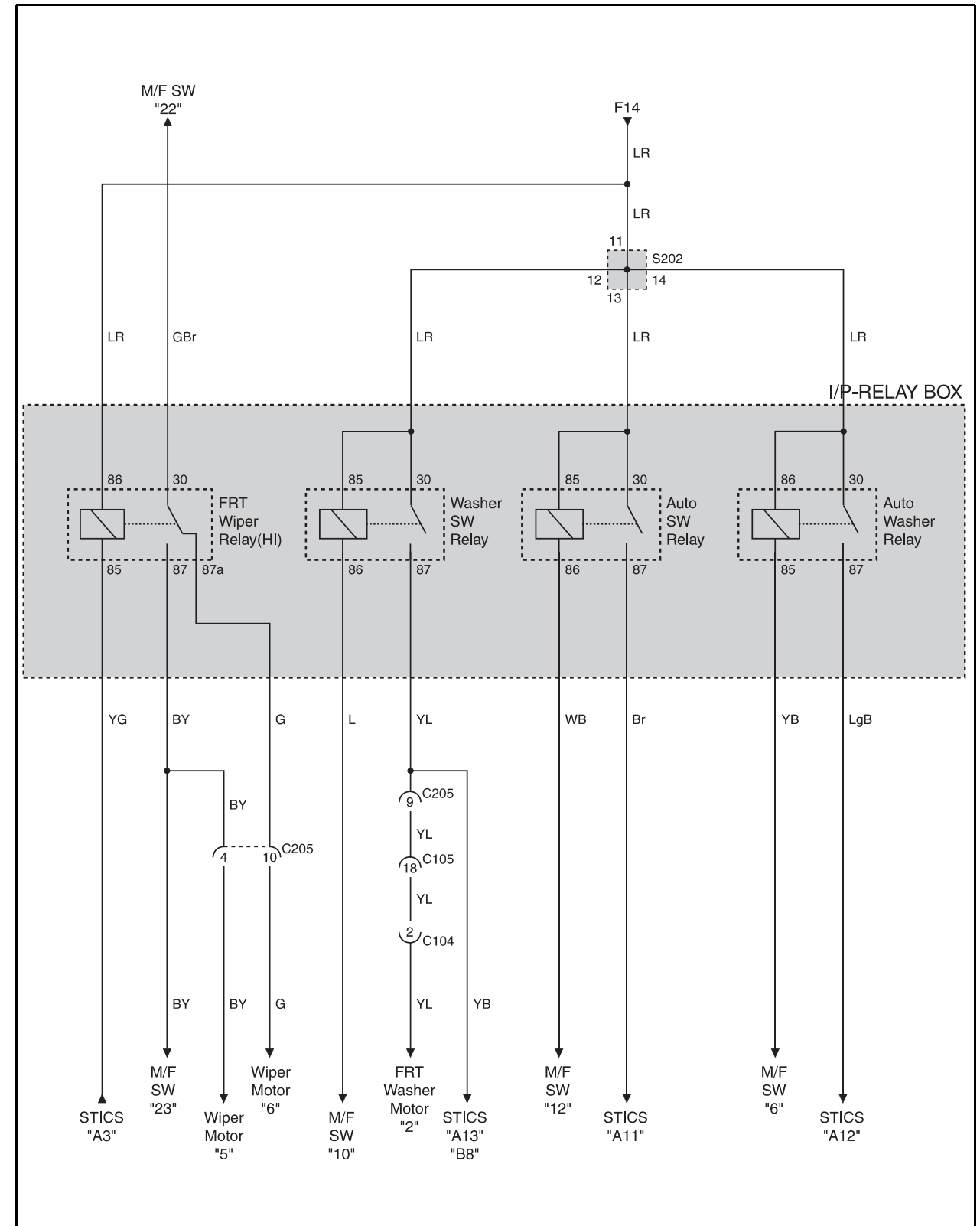

Modification basis	
Application basis	
Affected VIN	

(3) HARZARD RELAY, FLASHER UNIT

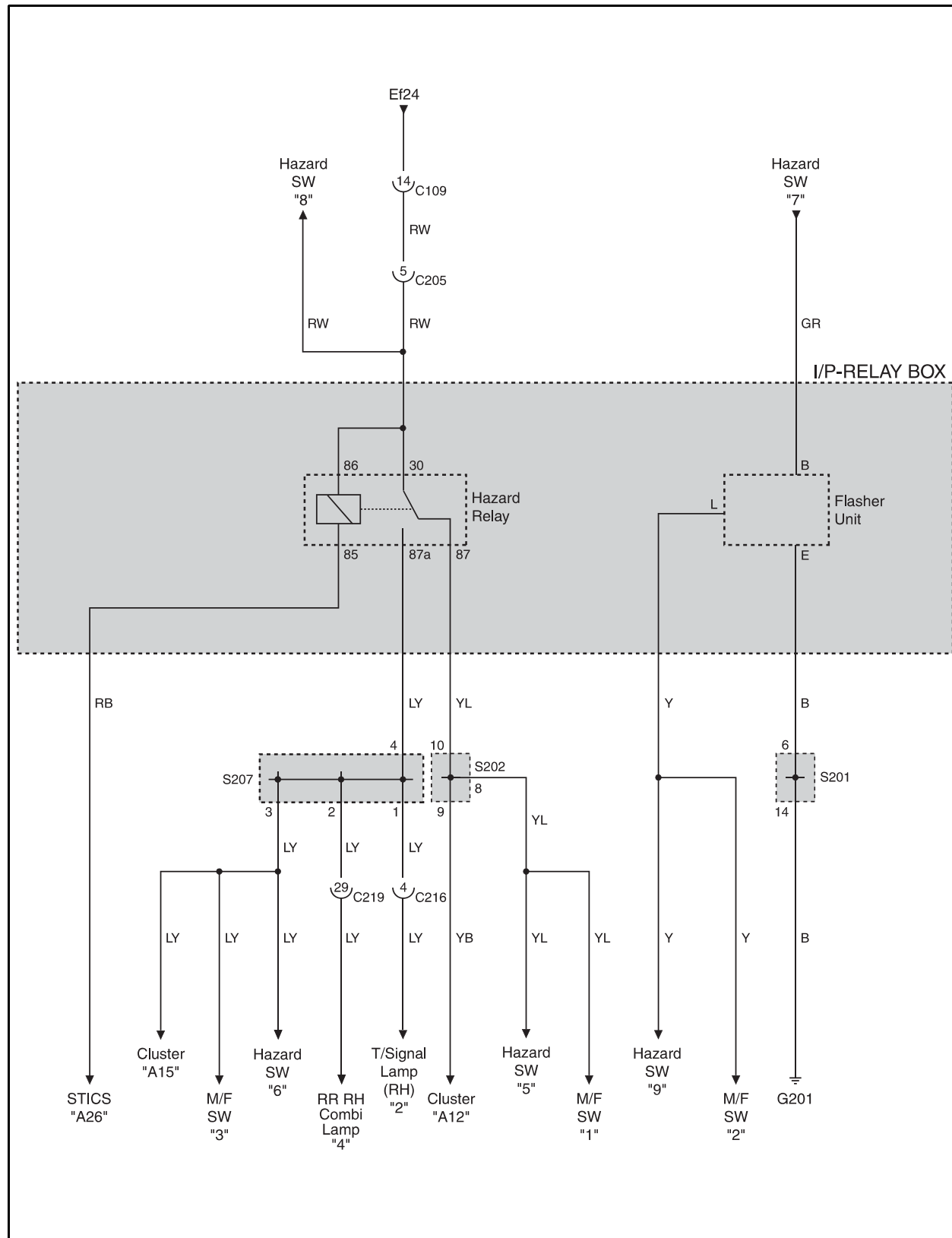

(3) DRL RELAY, RR FOG LAMP RELAY, RR WIPER RELAY

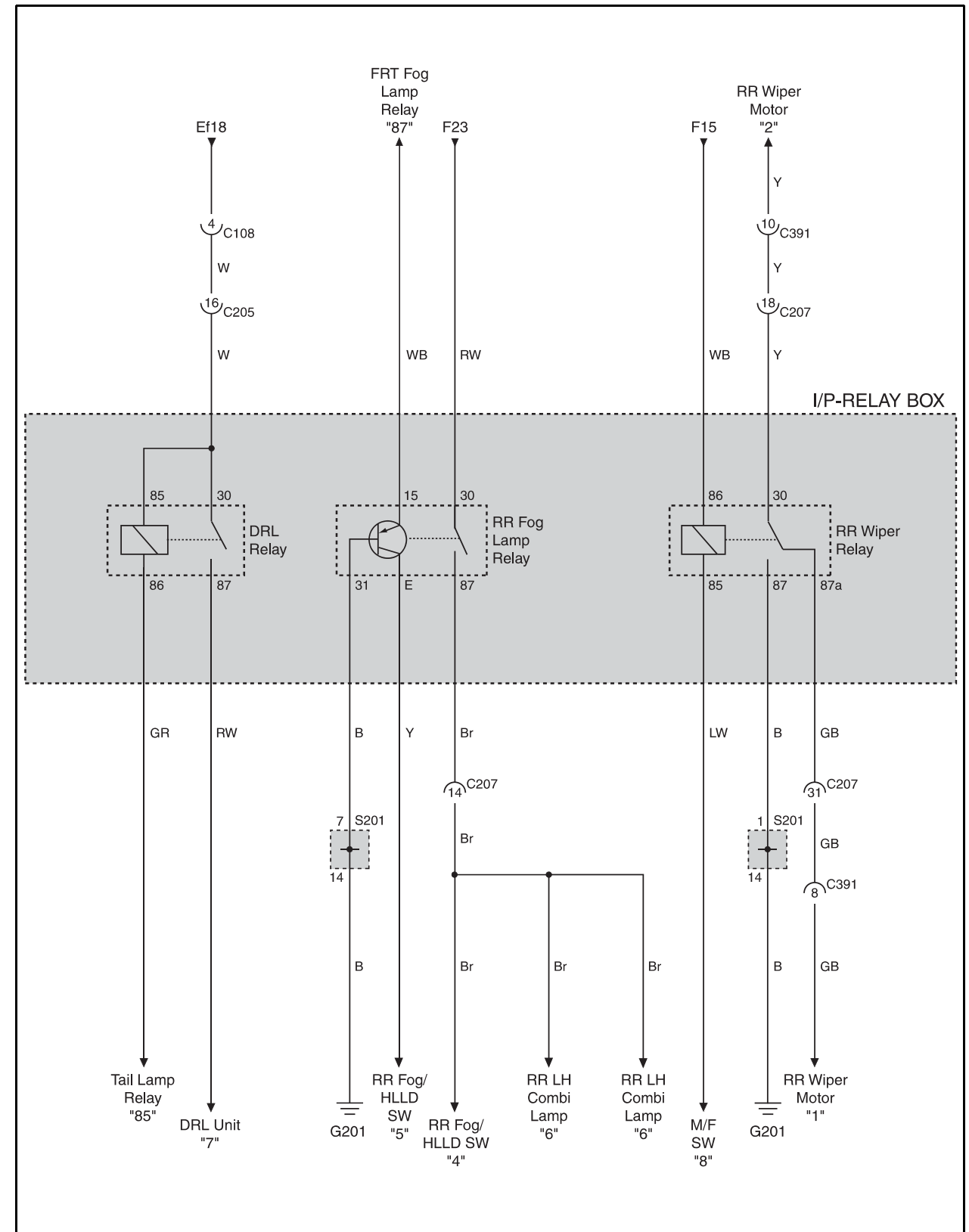

Modification basis	
Application basis	
Affected VIN	

(5) F/PUMP RELAY, INJ/IGN RELAY, SNR RELAY

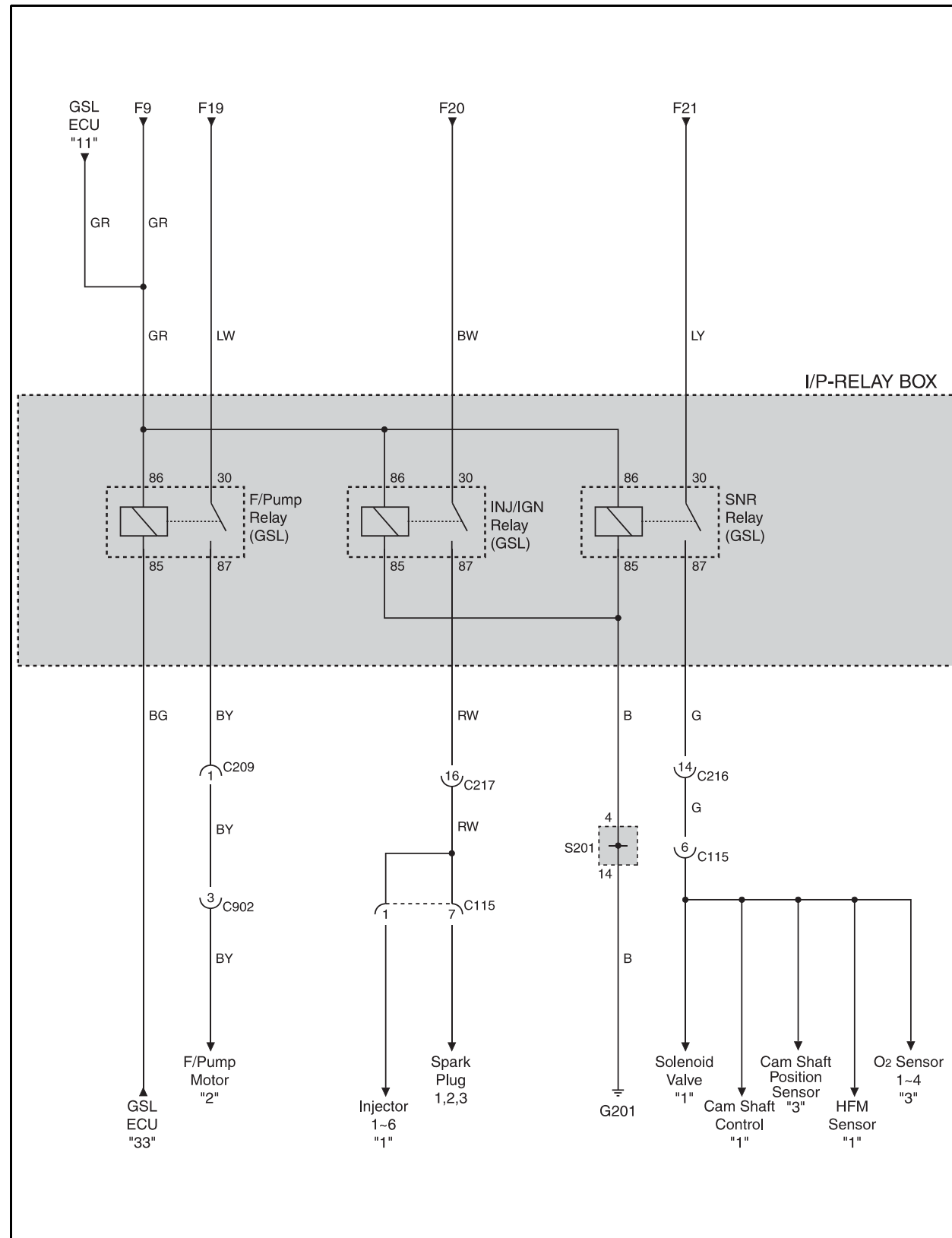

Modification basis	
Application basis	
Affected VIN	

